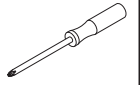
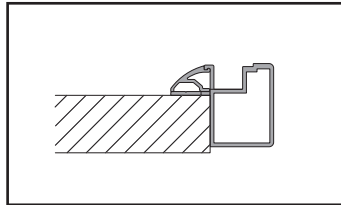
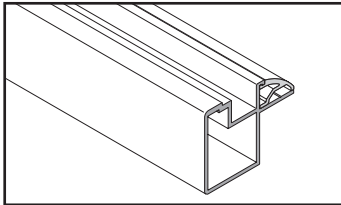
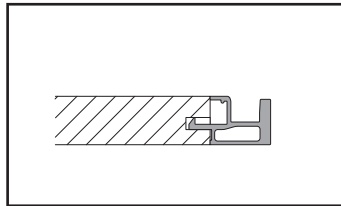
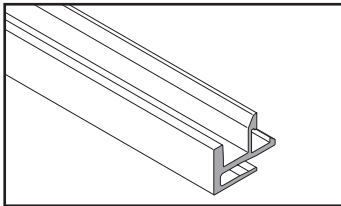
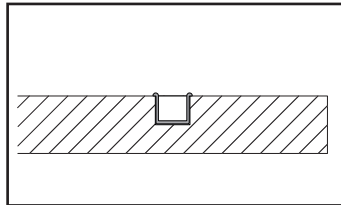
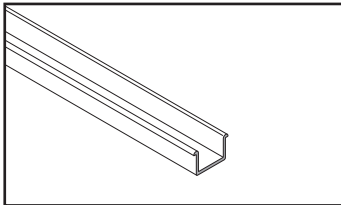
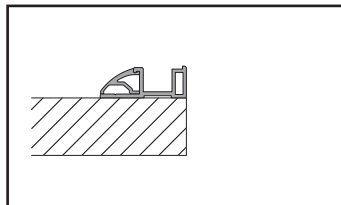
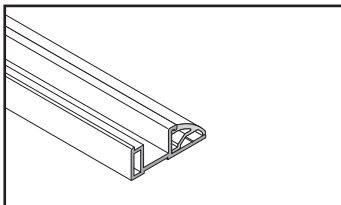
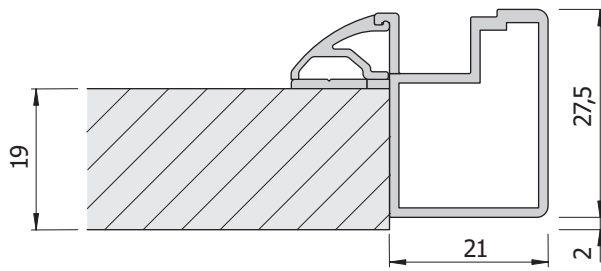
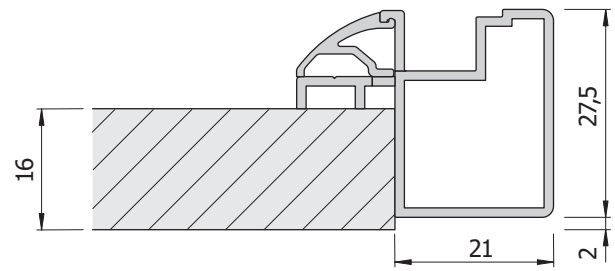
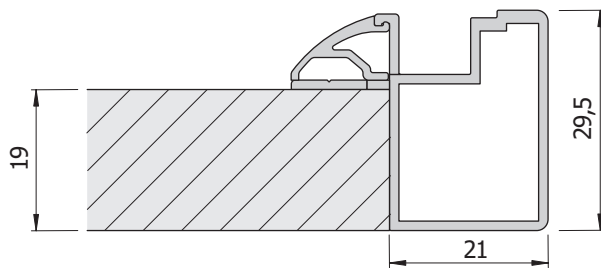
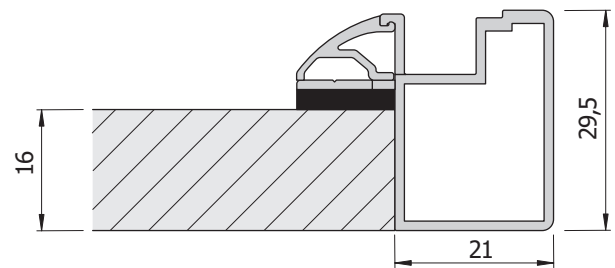
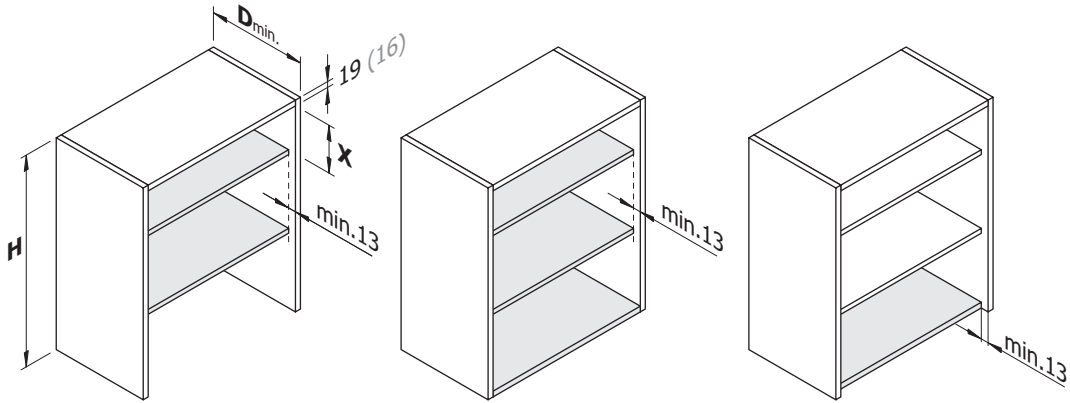

 mm  

**contour**

**frame**

**classic**

**slim line**

[www.knoke.eu/smart-case-de](http://www.knoke.eu/smart-case-de)

[www.knoke.eu/smart-case-en](http://www.knoke.eu/smart-case-en)

**contour****19-2****16-2****19-0****16-0**



H	D <sub>min.</sub>	X	
		19	16
250 - 1600	329	155	158



H	D <sub>min.</sub>	X	
		19	16
250 - 1600	329	155	158

A	2

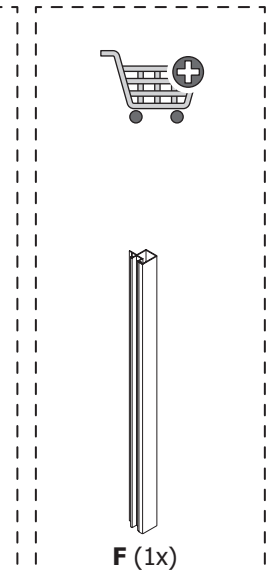
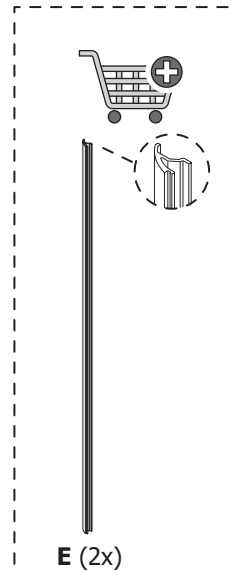
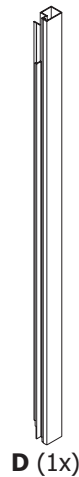
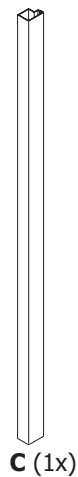
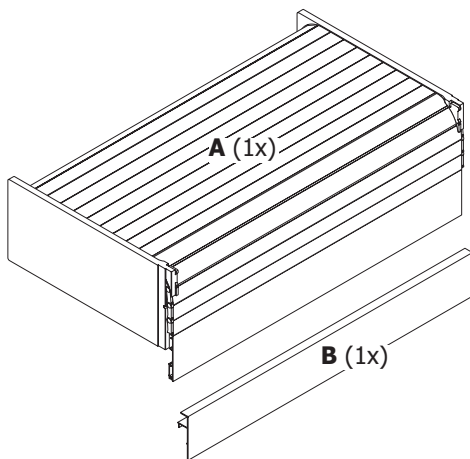
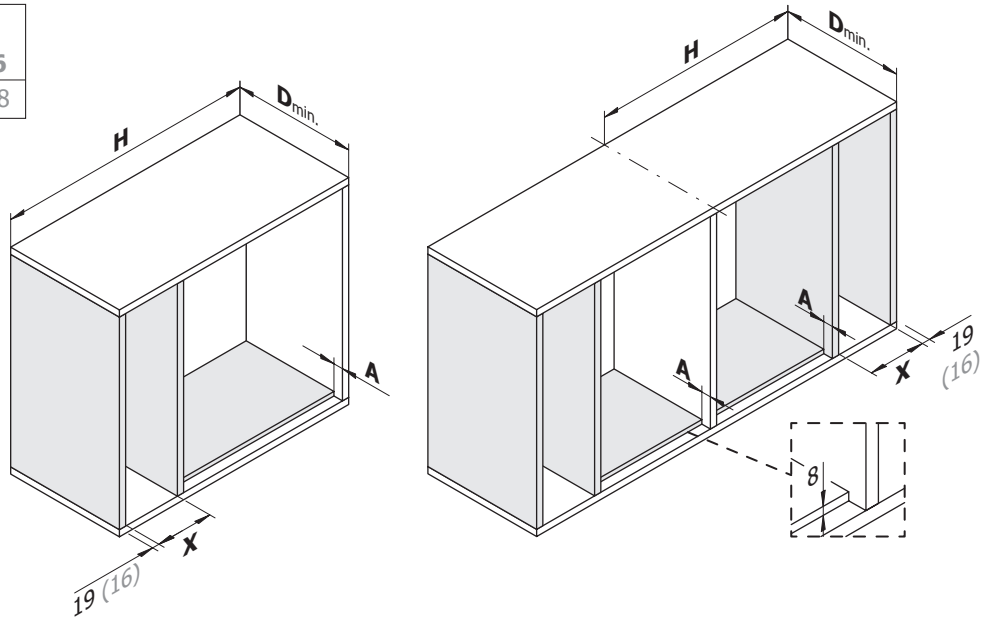



1

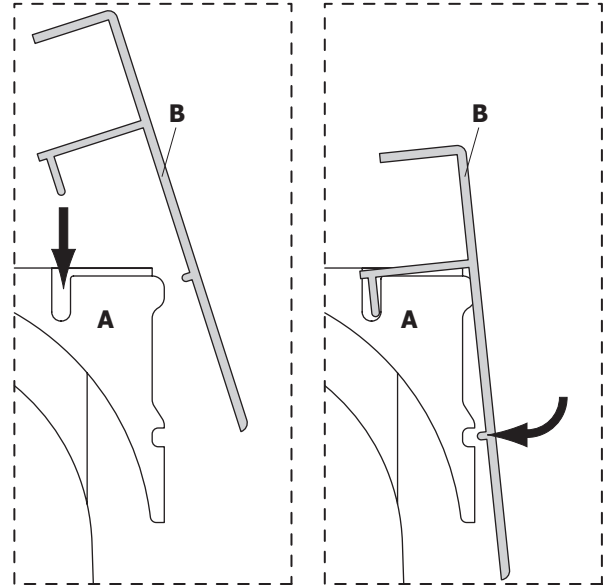
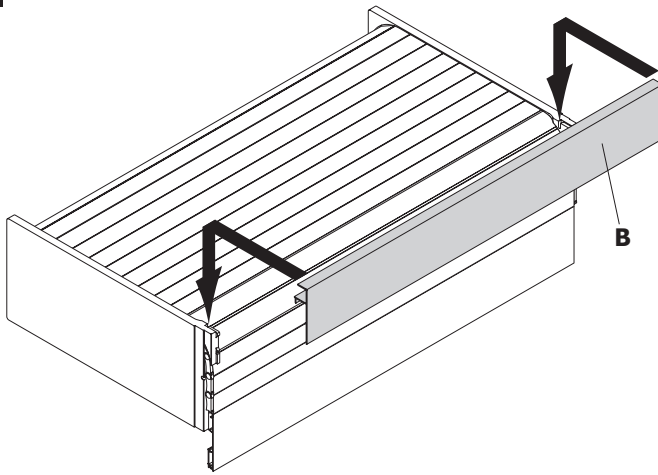

2

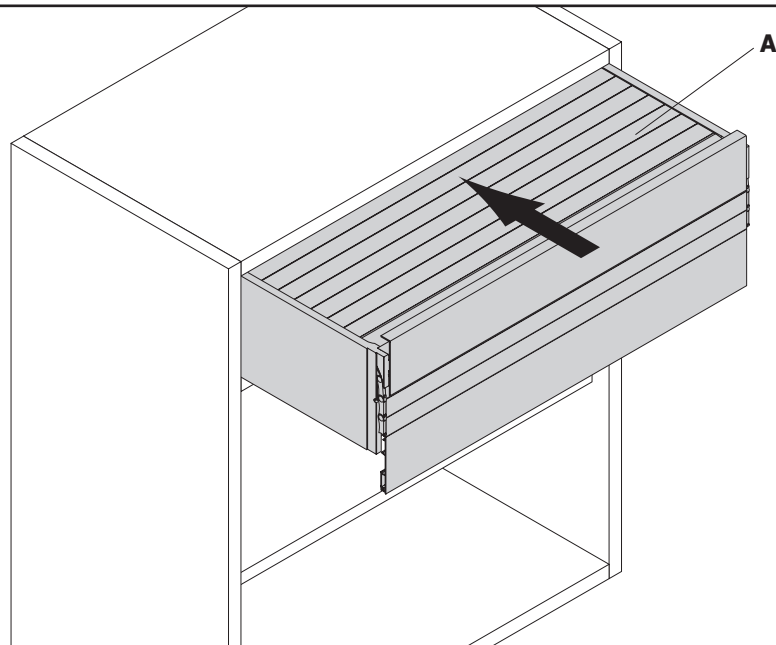

3

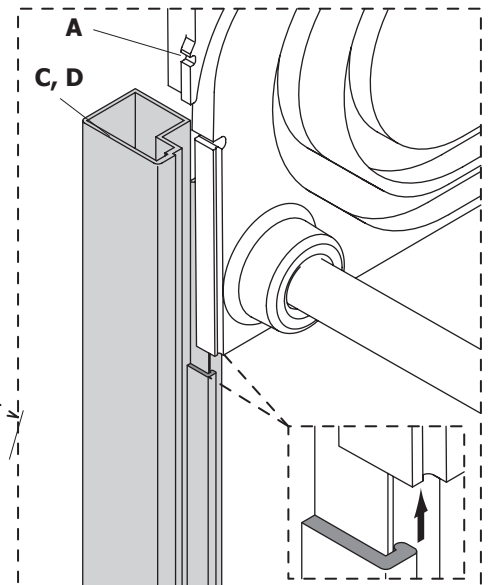
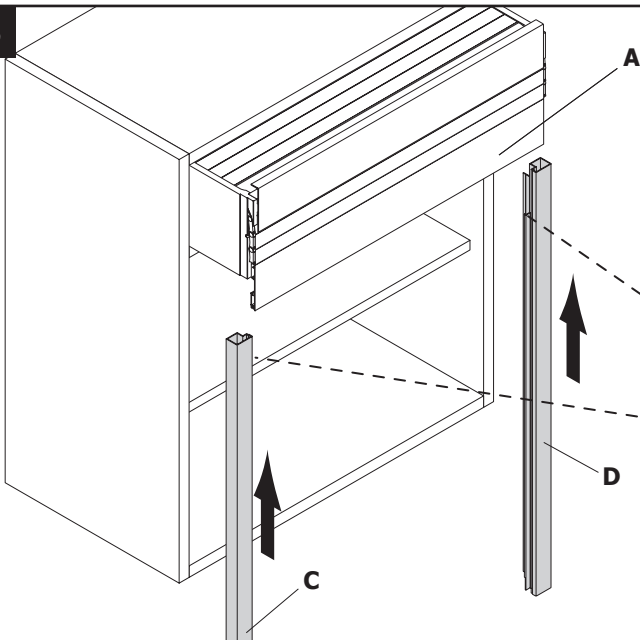

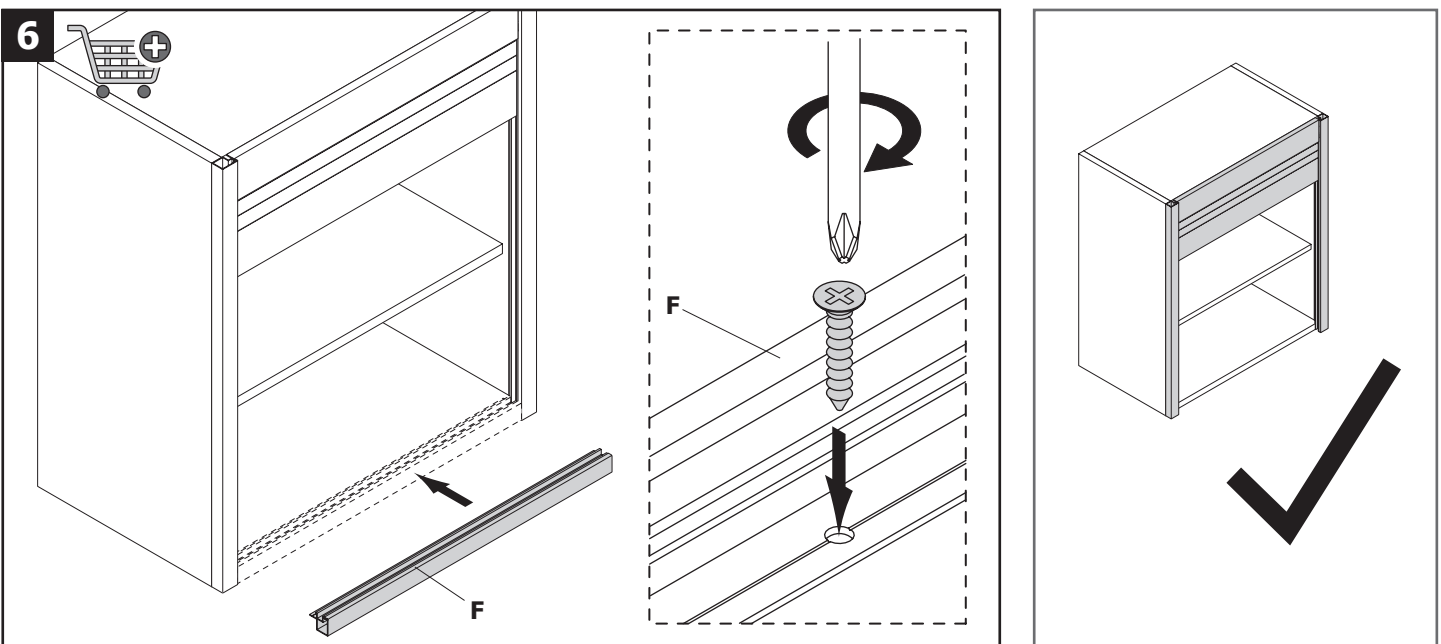
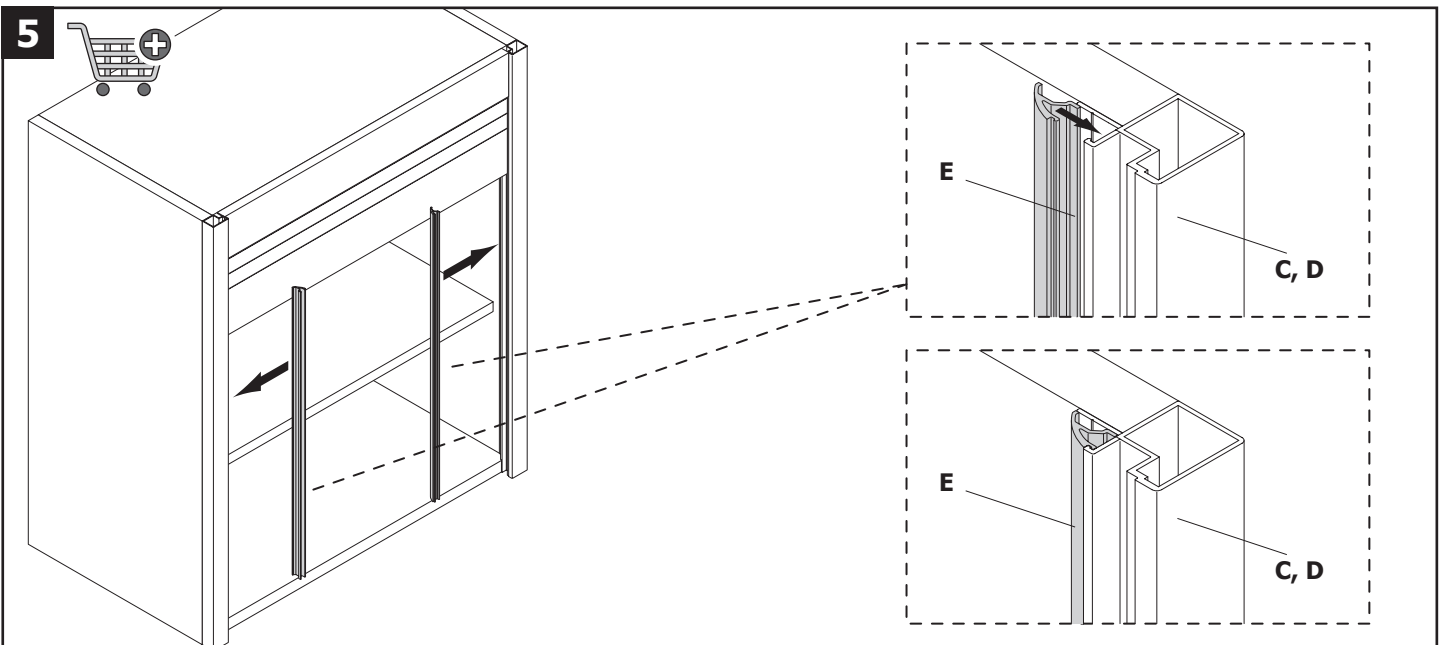
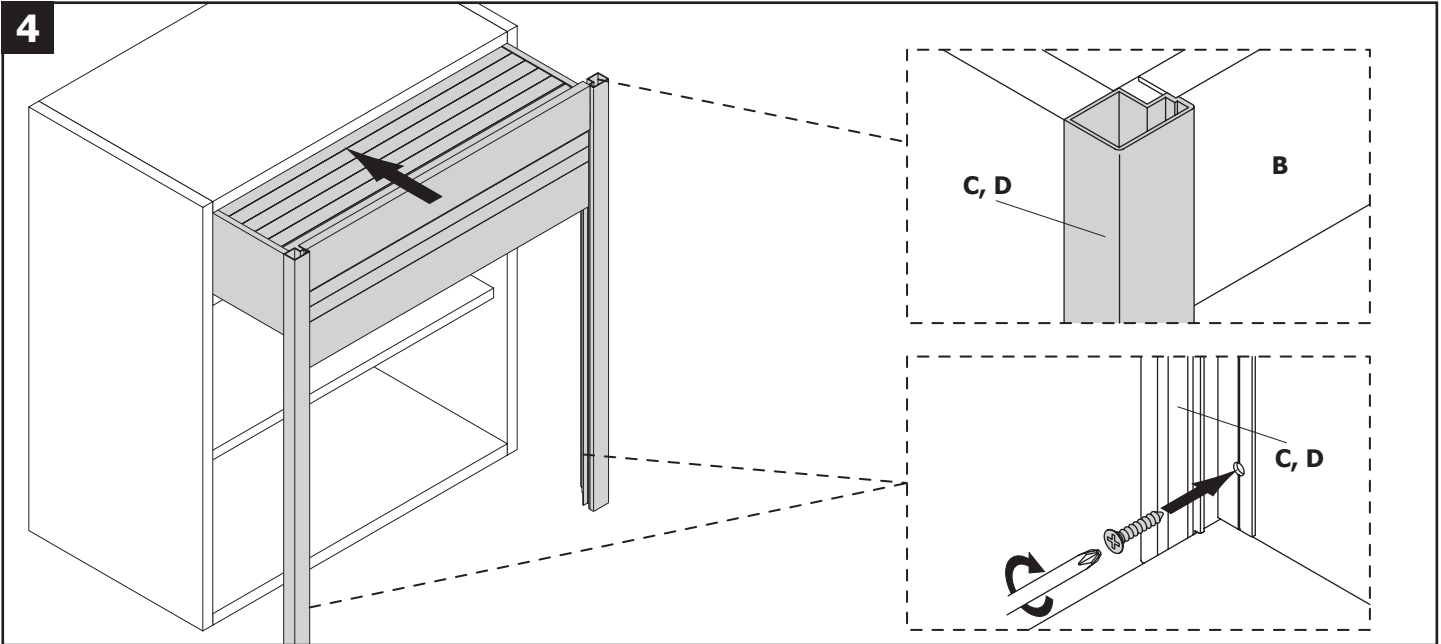

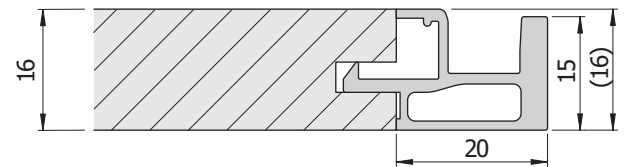
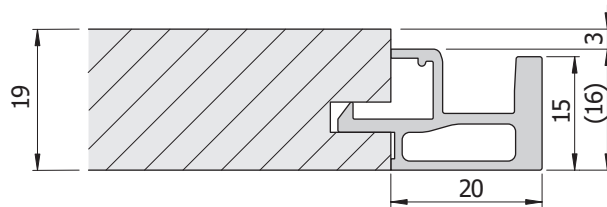
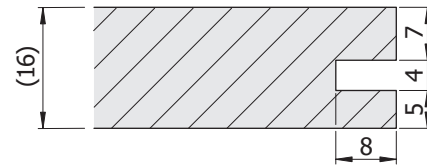
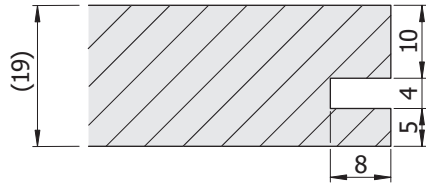
**frame**



H	D <sub>min.</sub>	X	
		19	16
250 - 1600	329	155	158

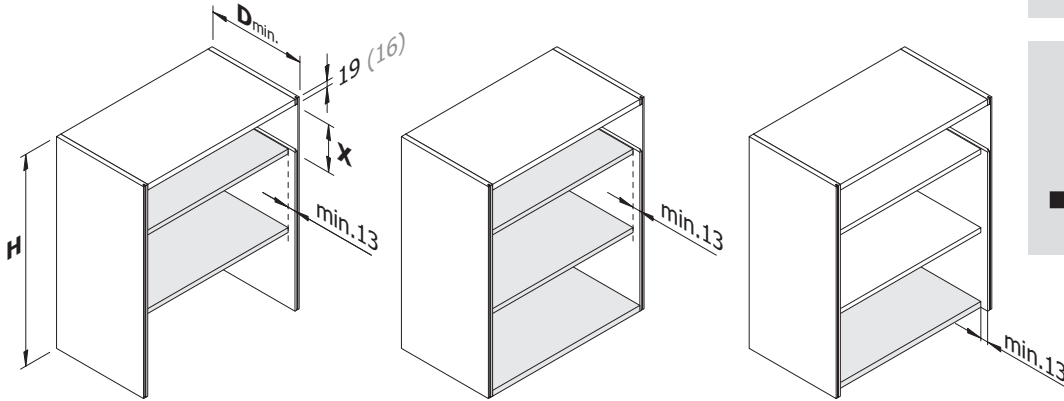
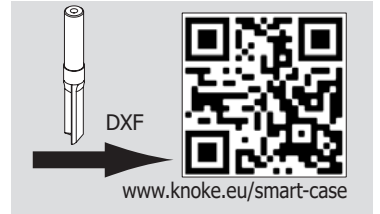

H	D <sub>min.</sub>	X	
		19	16
250 - 1600	329	155	158

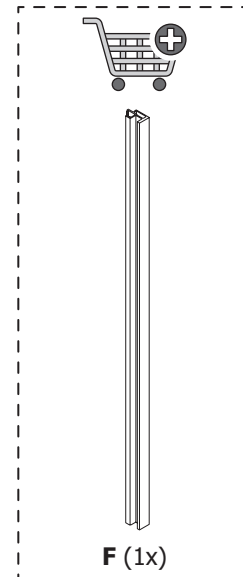
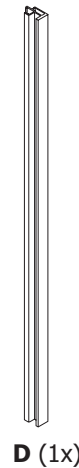
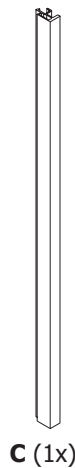
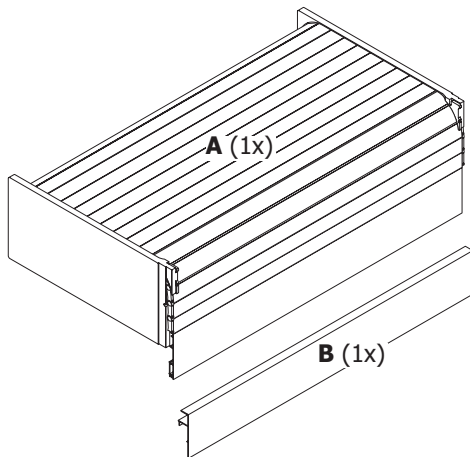
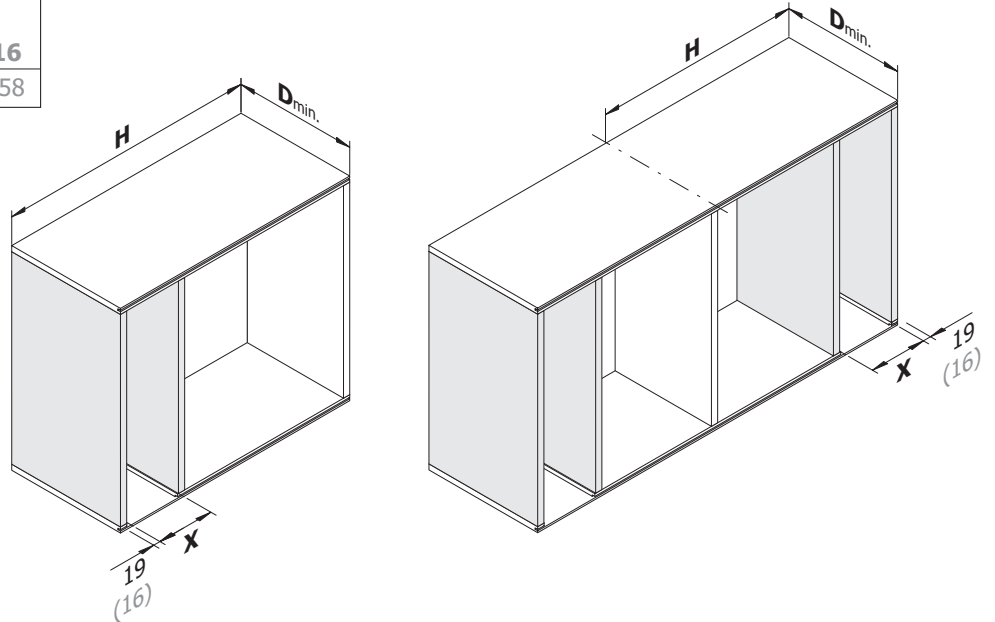



1

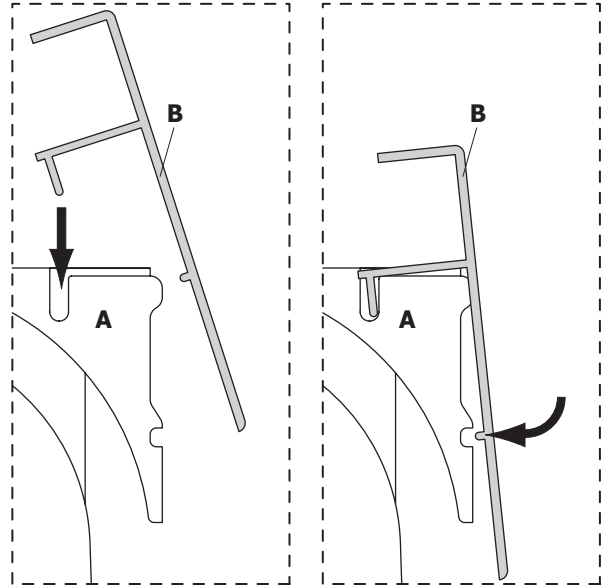
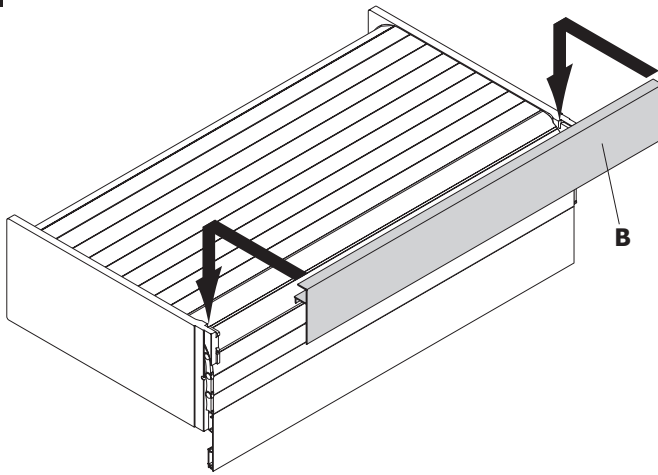

2

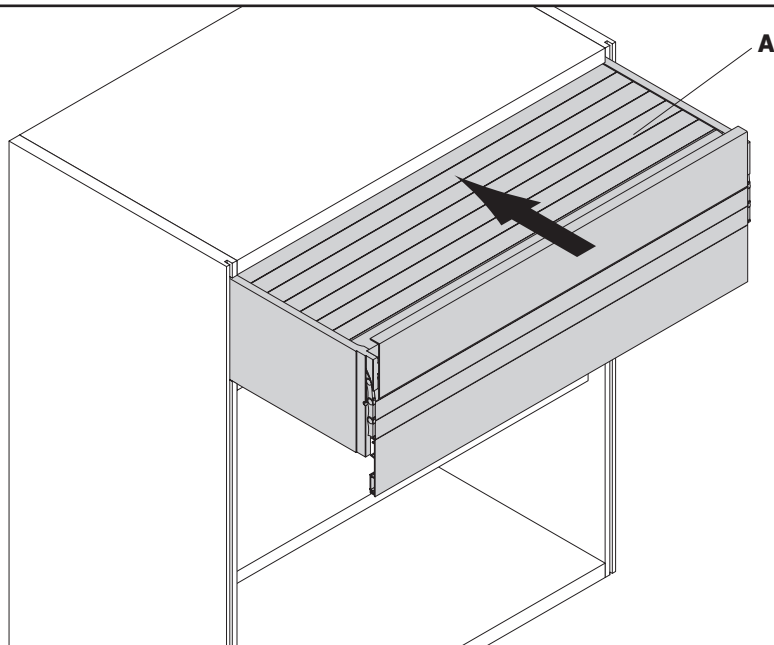

3

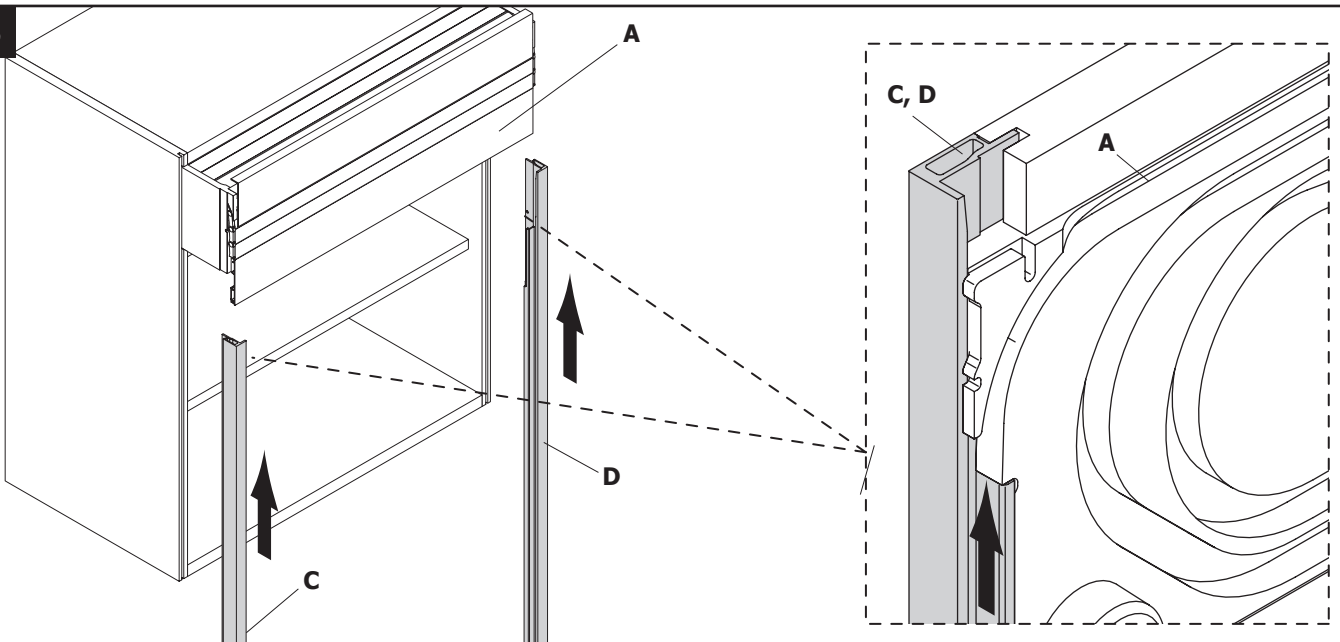



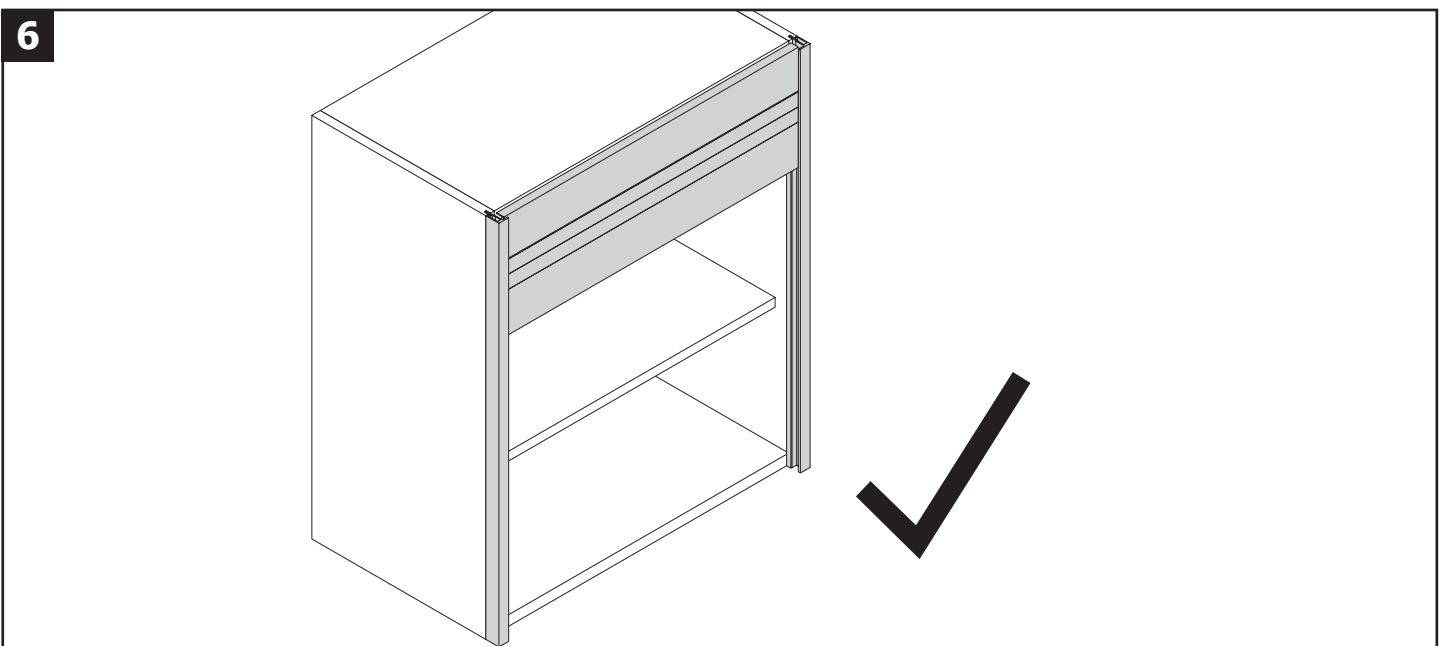
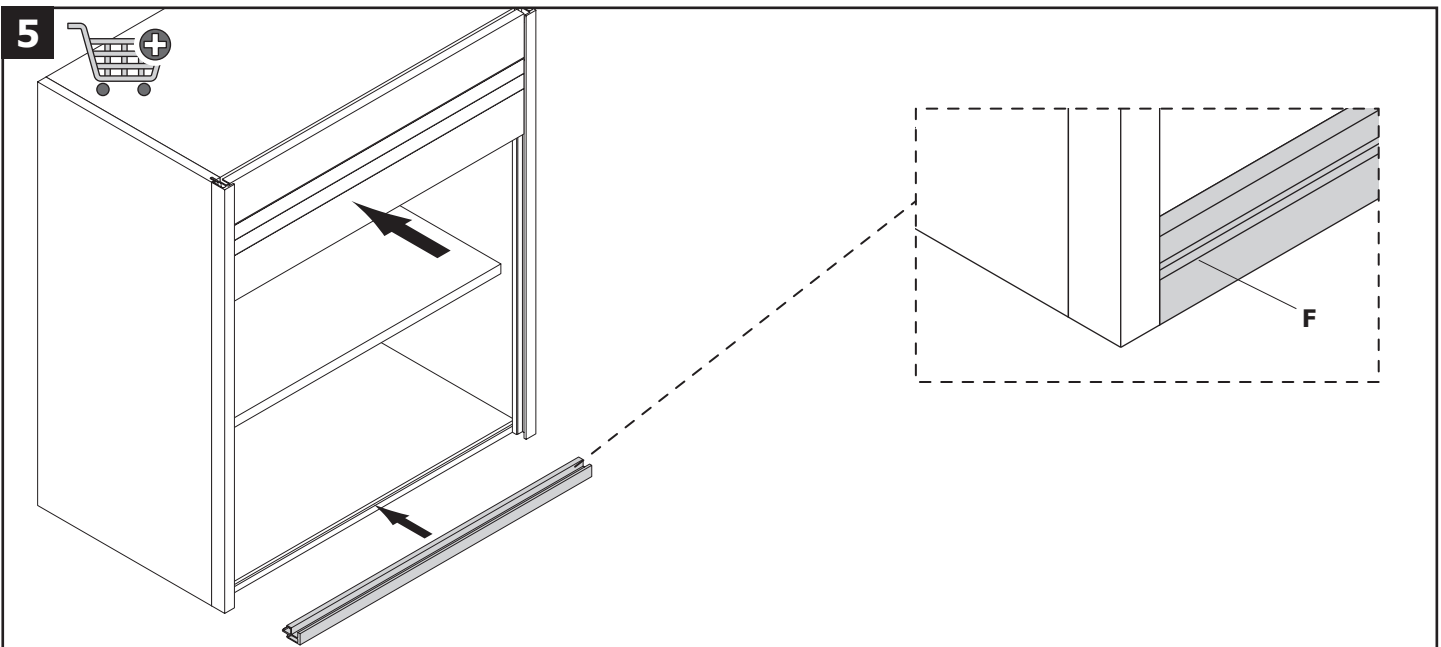
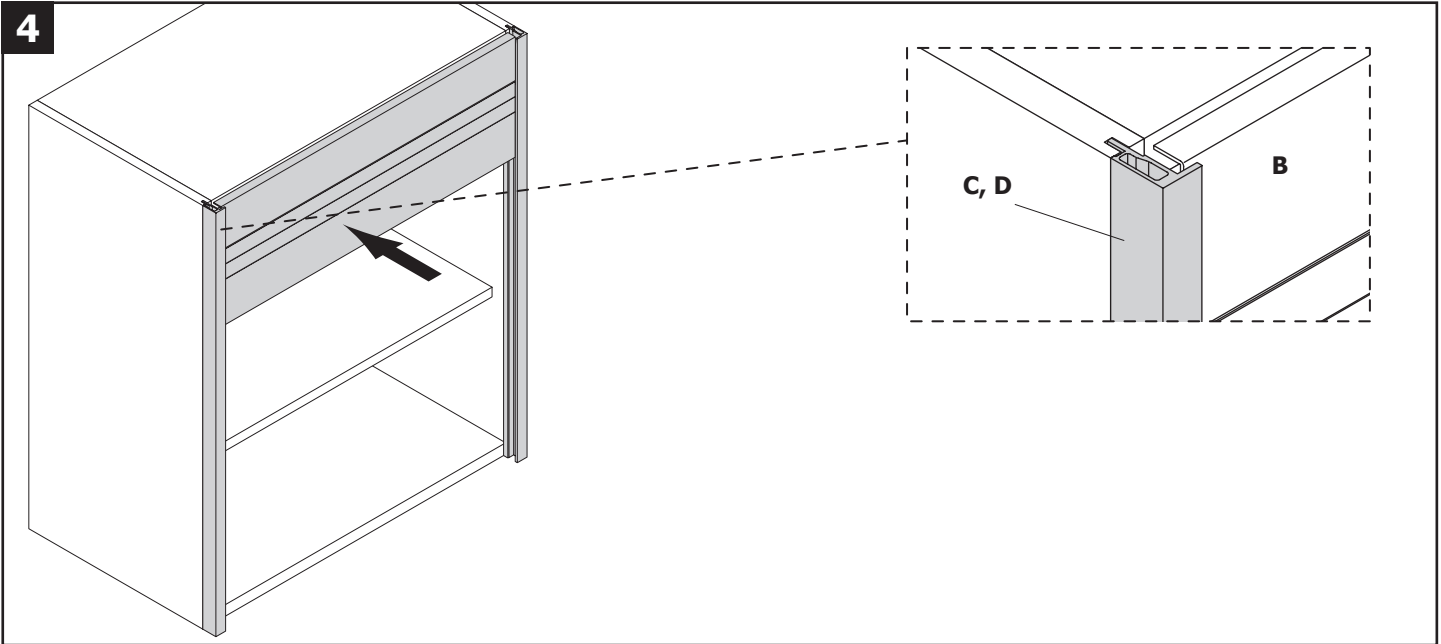

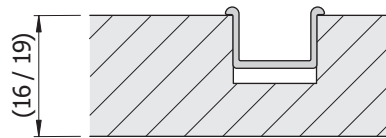
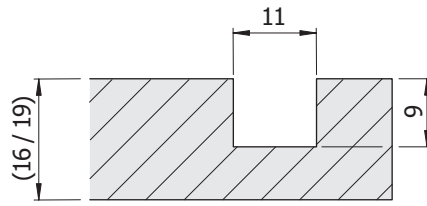
**classic**



H	D <sub>min.</sub>	X	
250 - 1600	350	19	16
		155	158

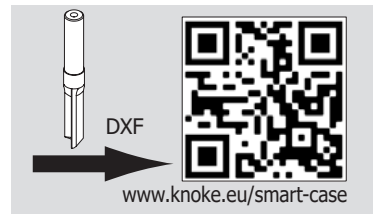
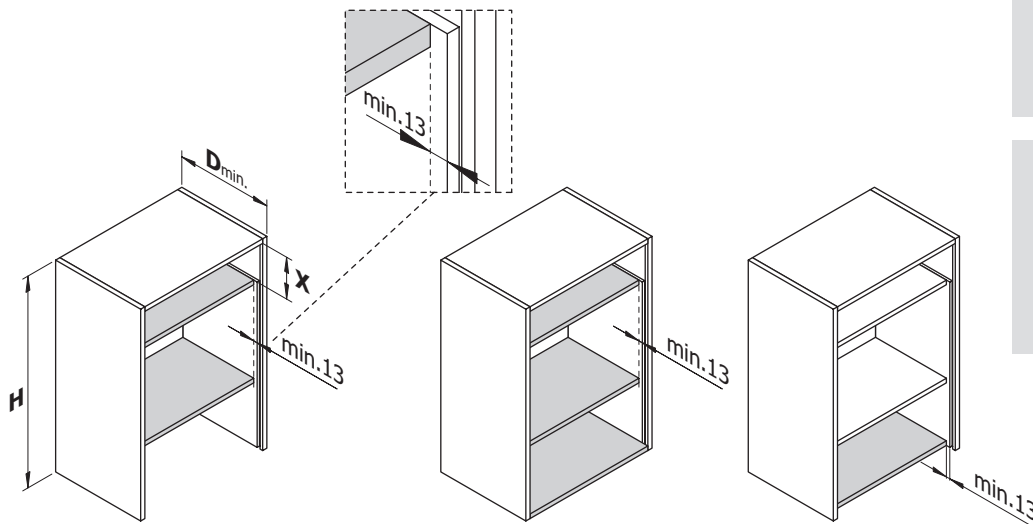

H	D <sub>min.</sub>	X	
250 - 1600	350	19	16
		155	158

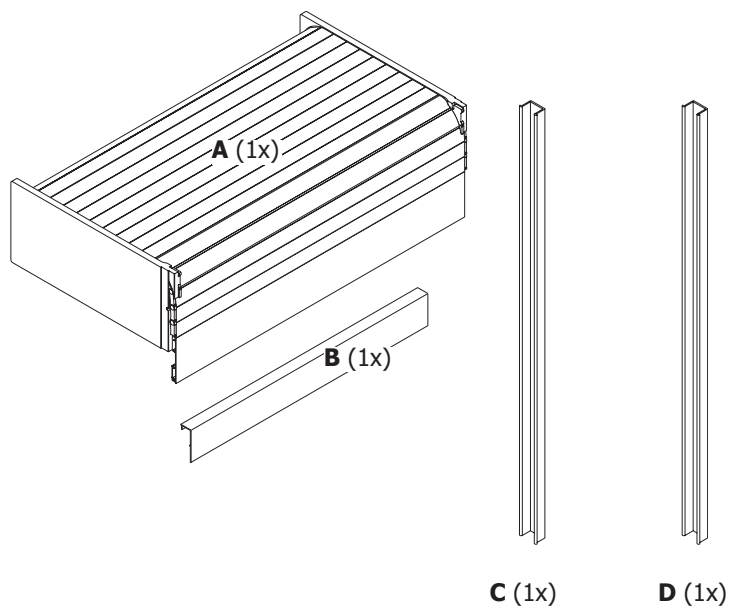
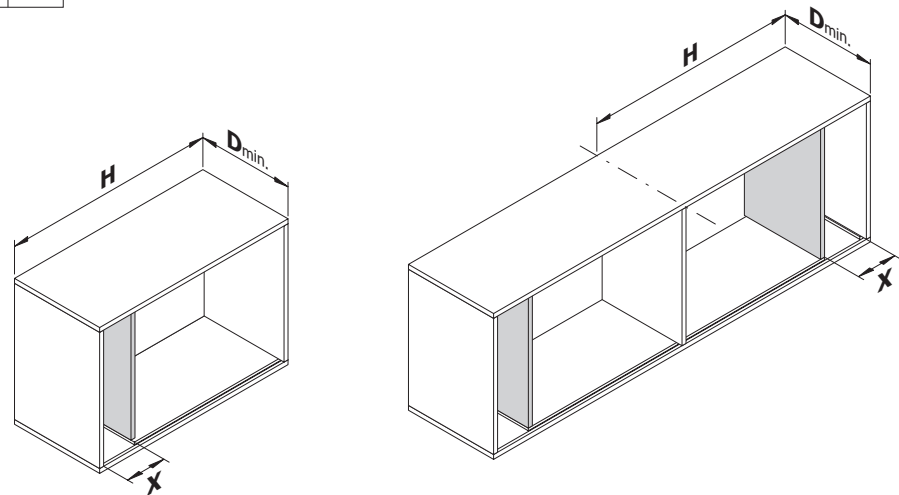



1

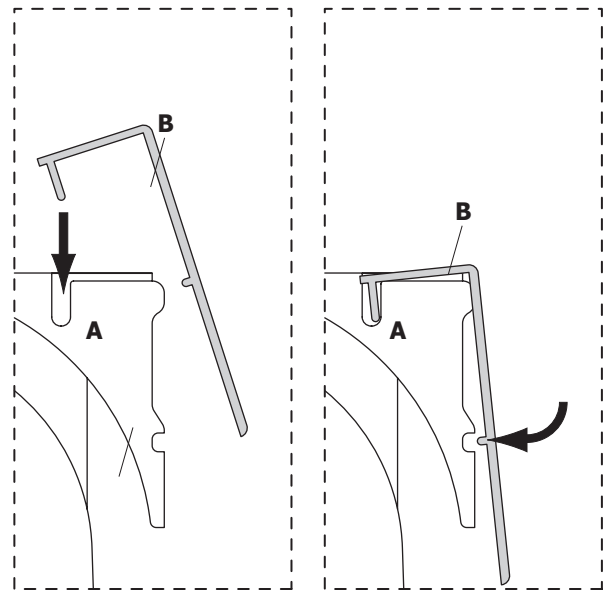
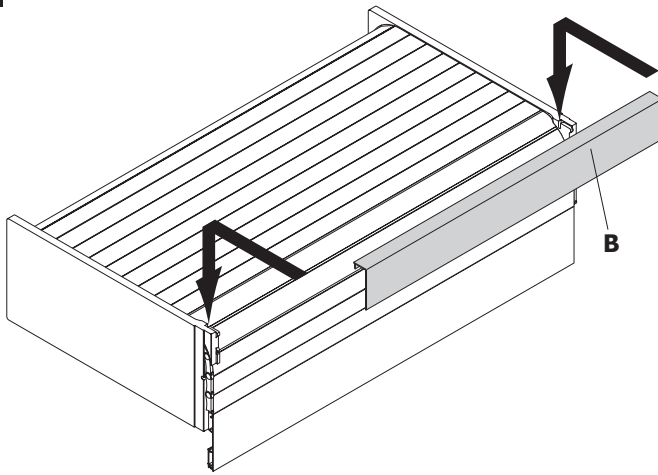

2

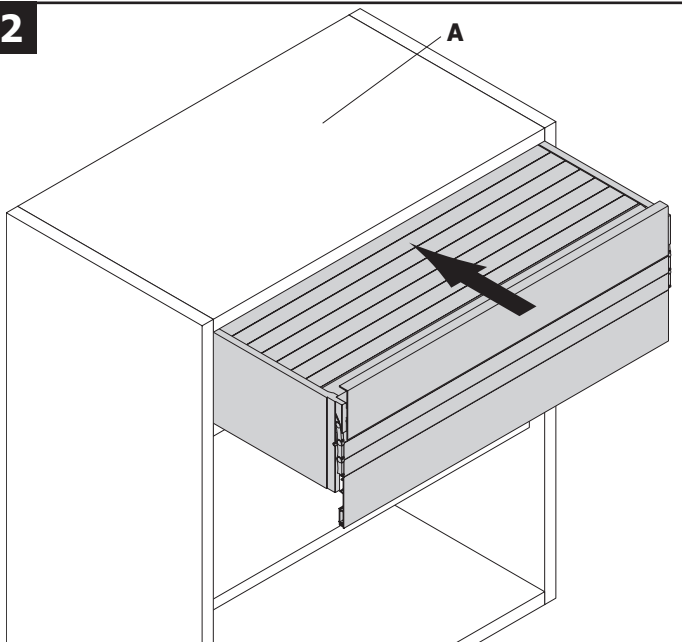

4

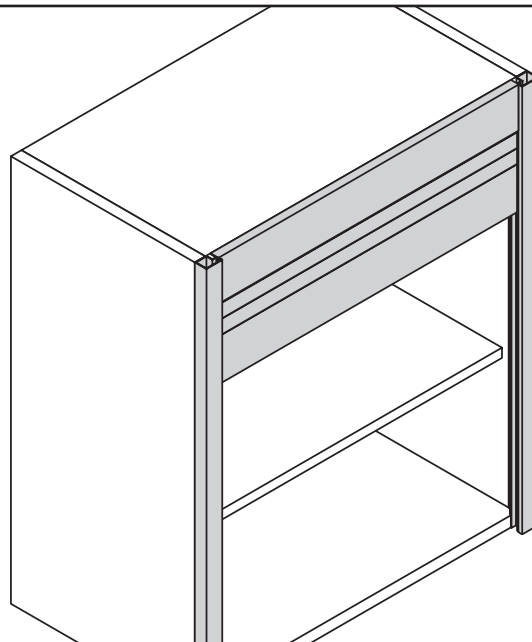
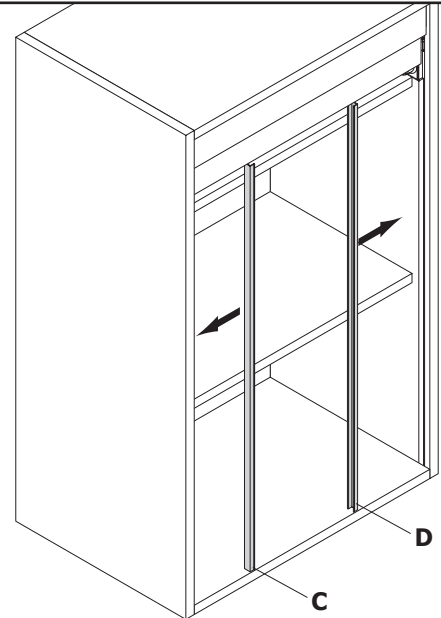

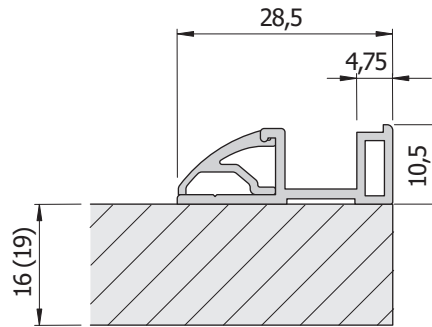
**slim-line**



H	D <sub>min.</sub>	X
250 - 1600	344	155

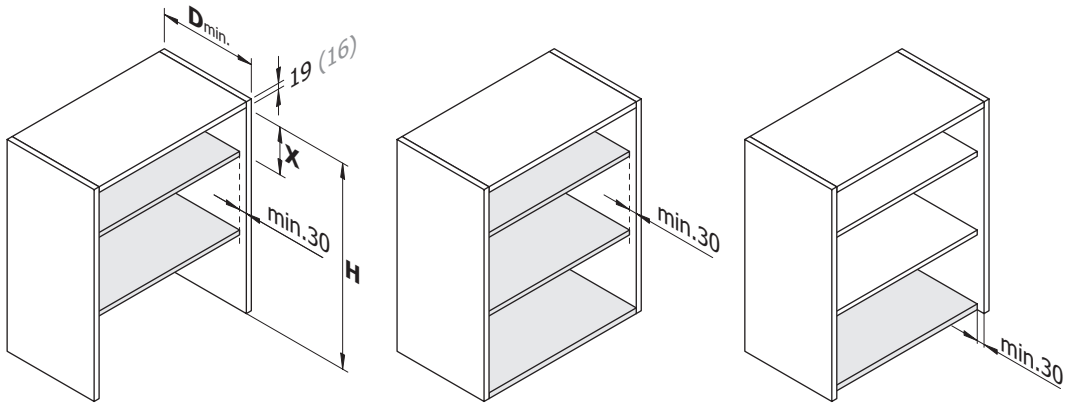

H	D <sub>min.</sub>	X
250 - 1600	344	155

<b>A</b> 17

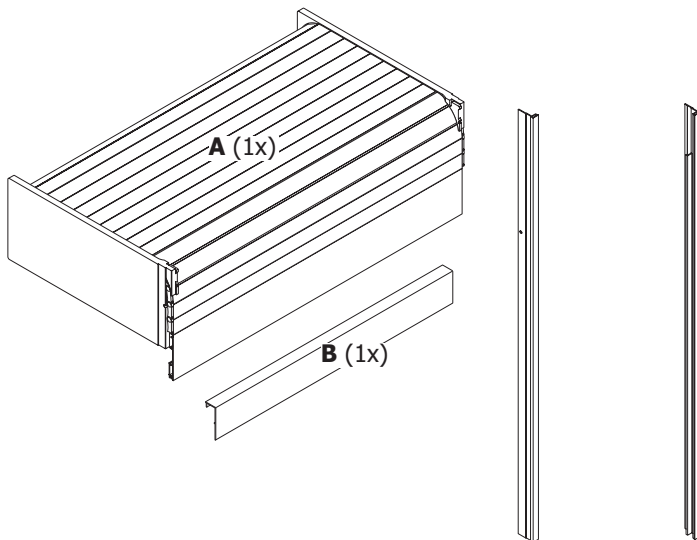
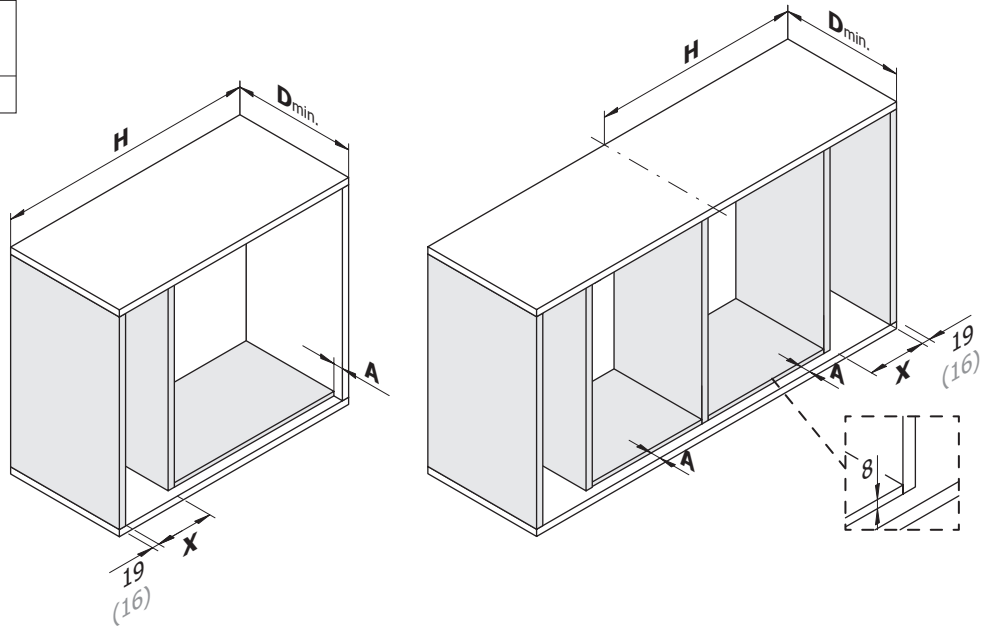



1

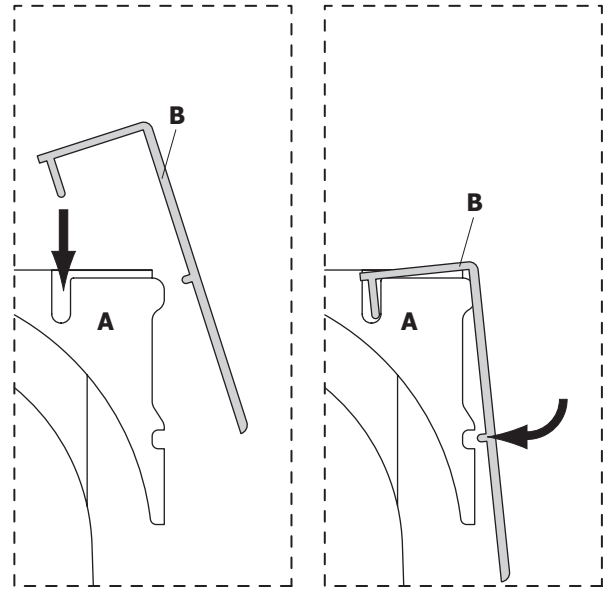
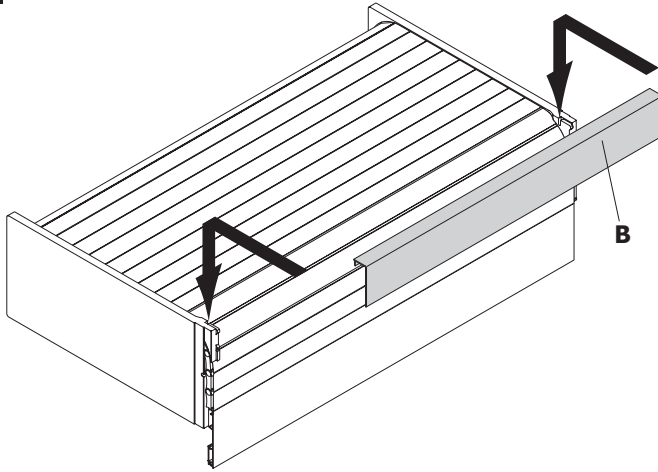

2

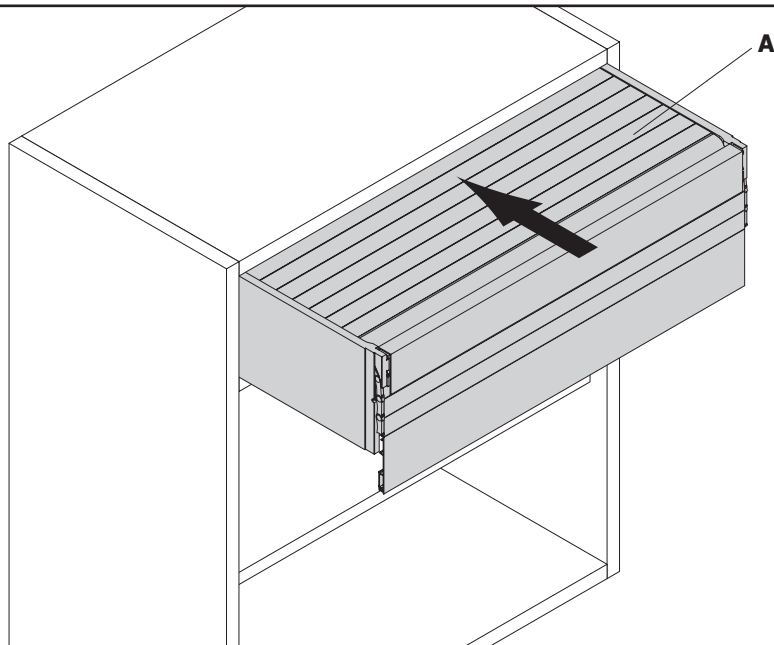

3

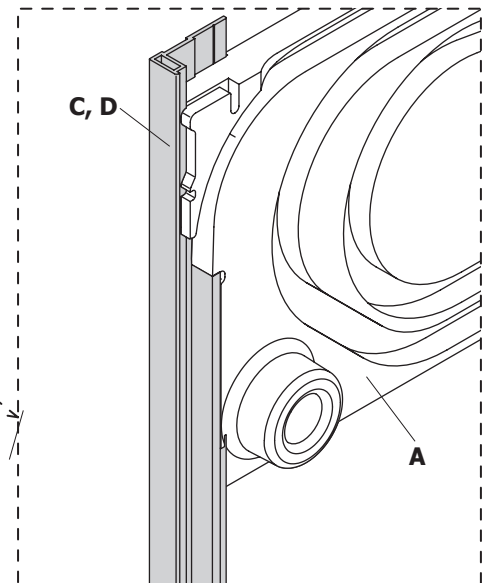
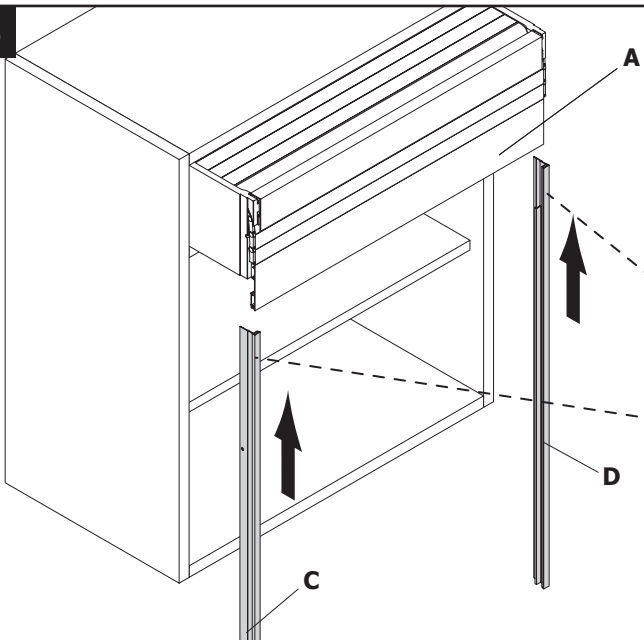

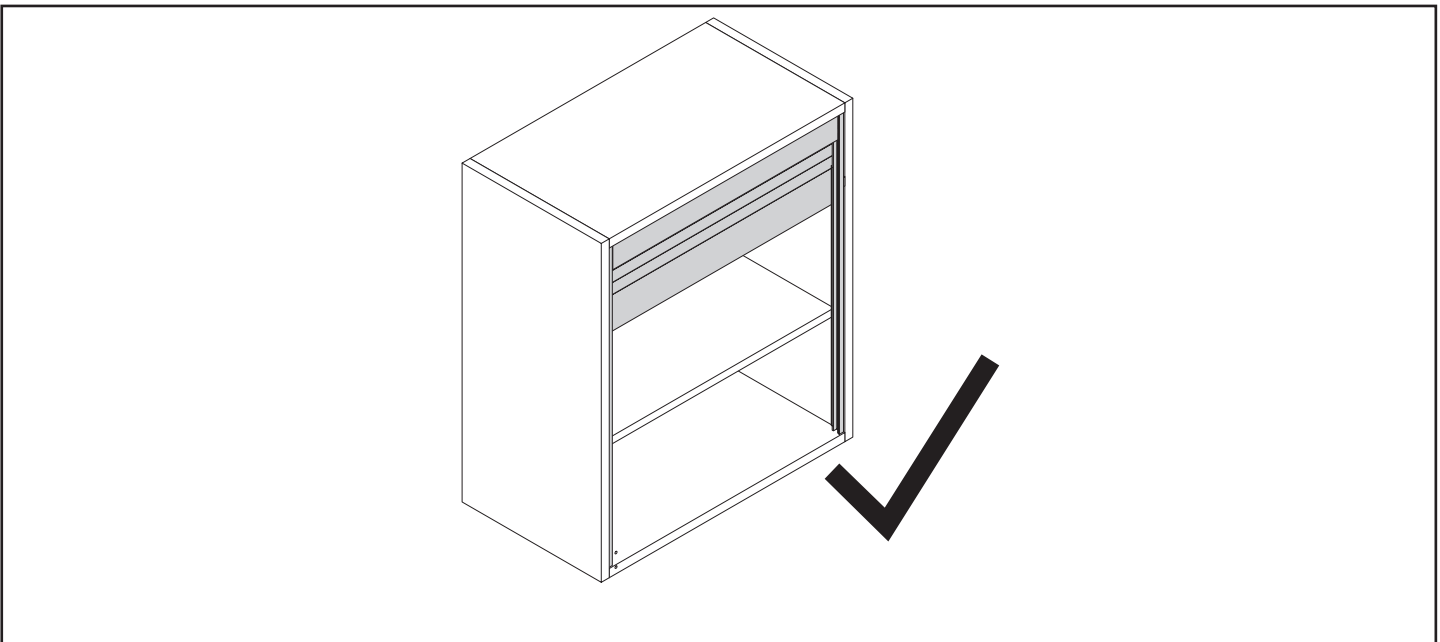
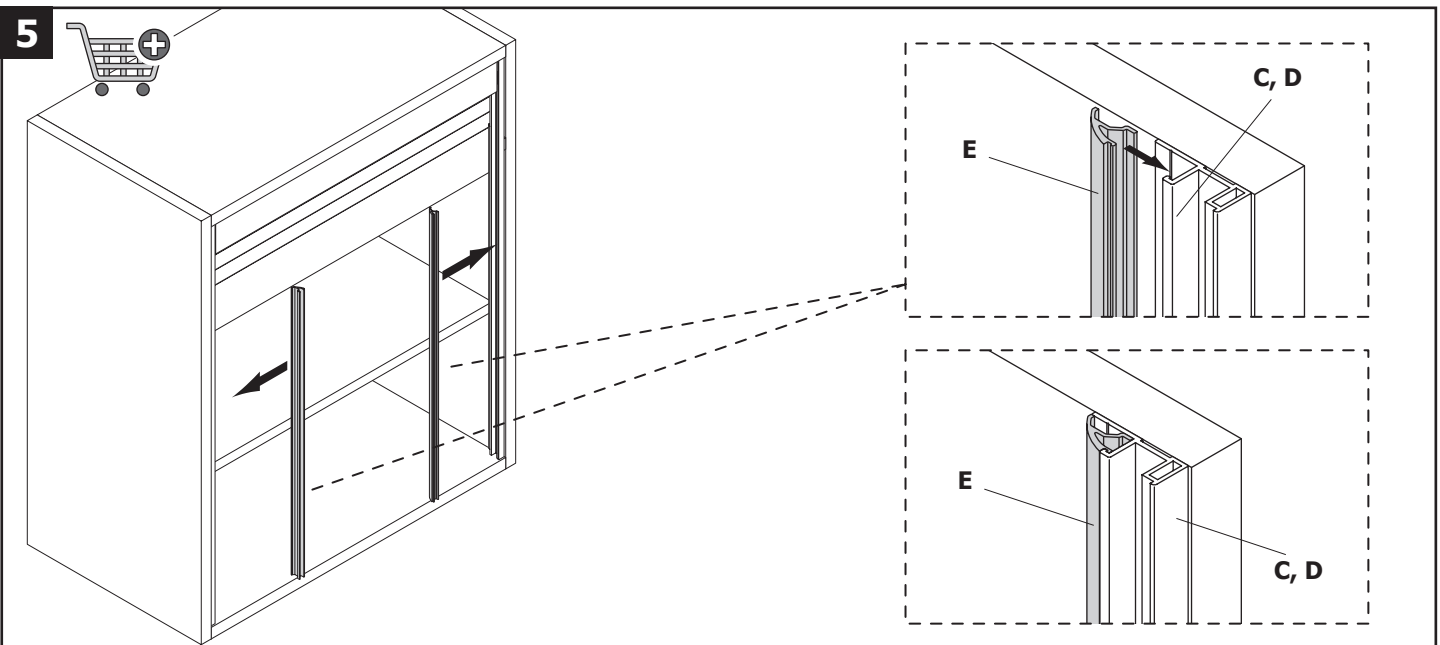
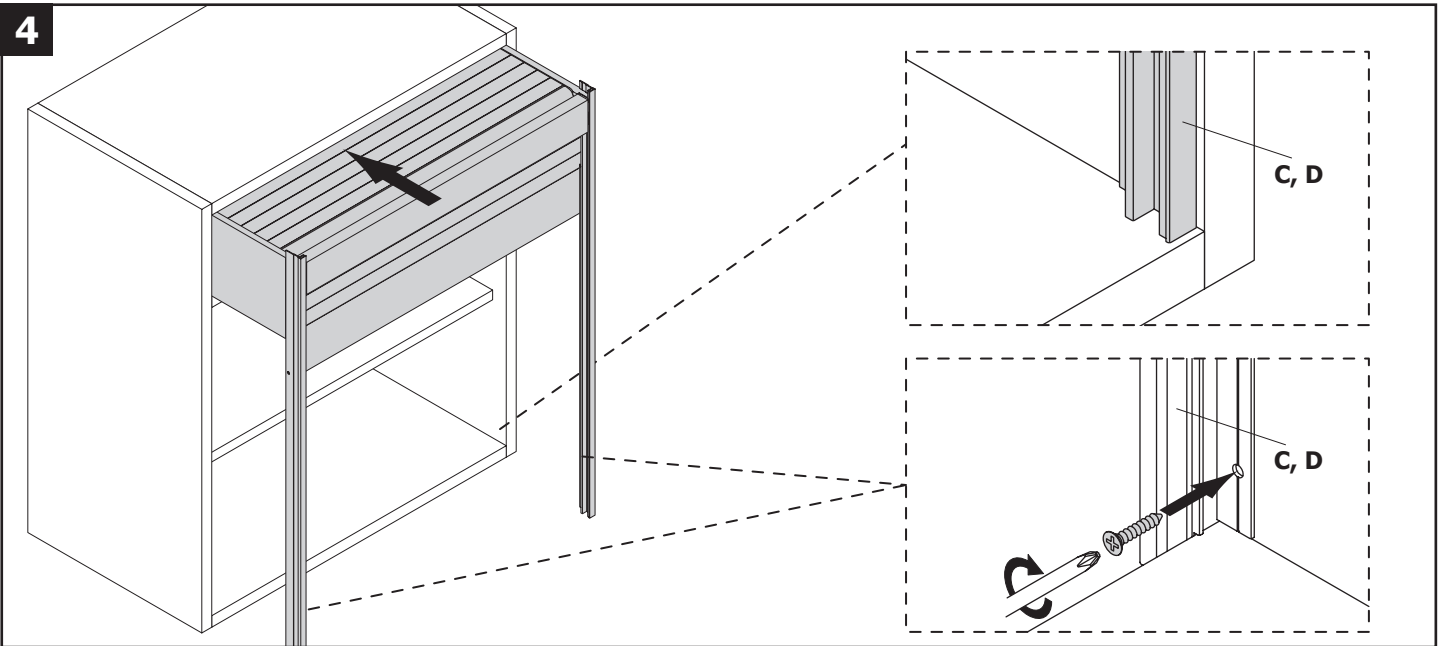



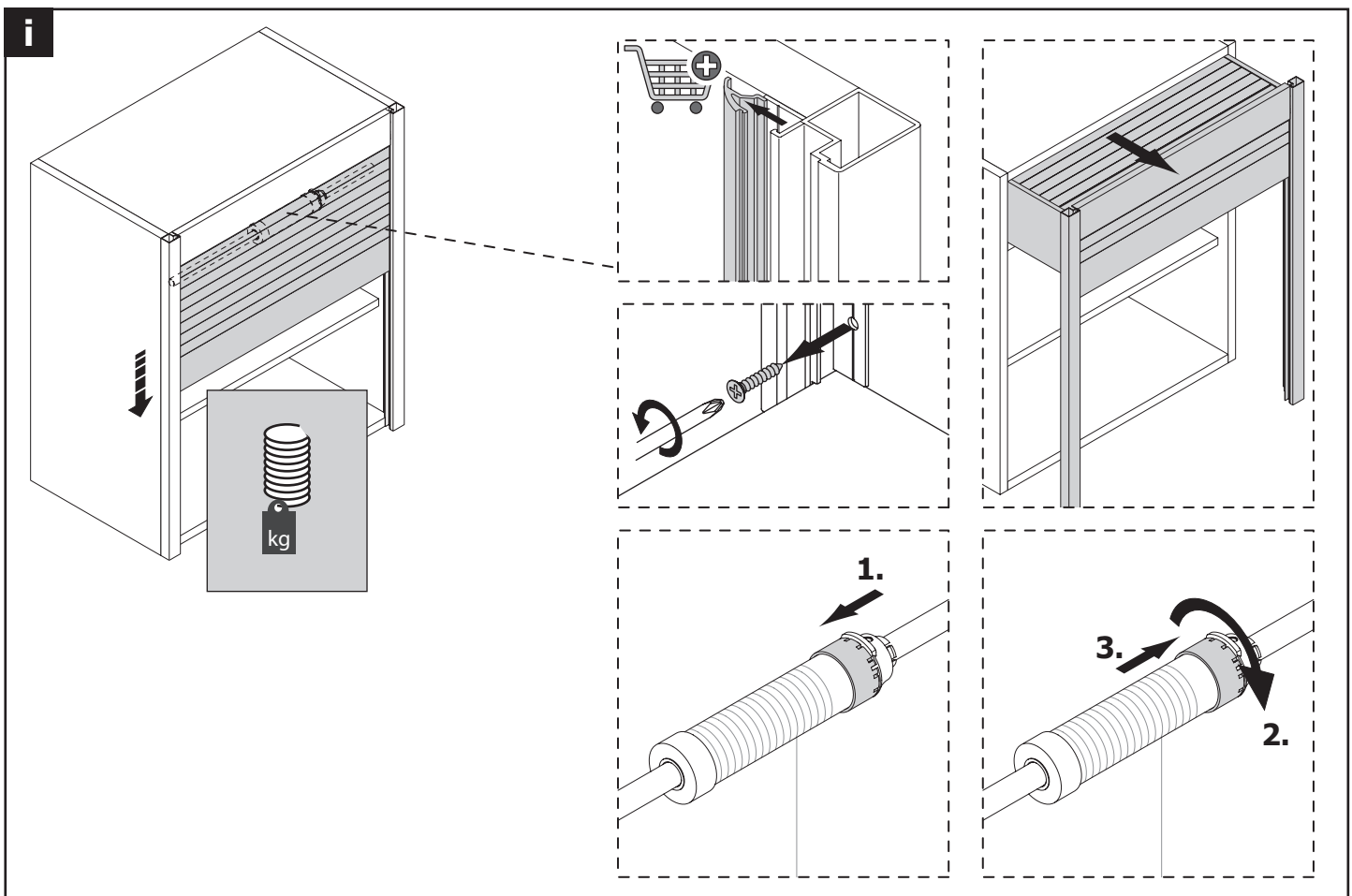
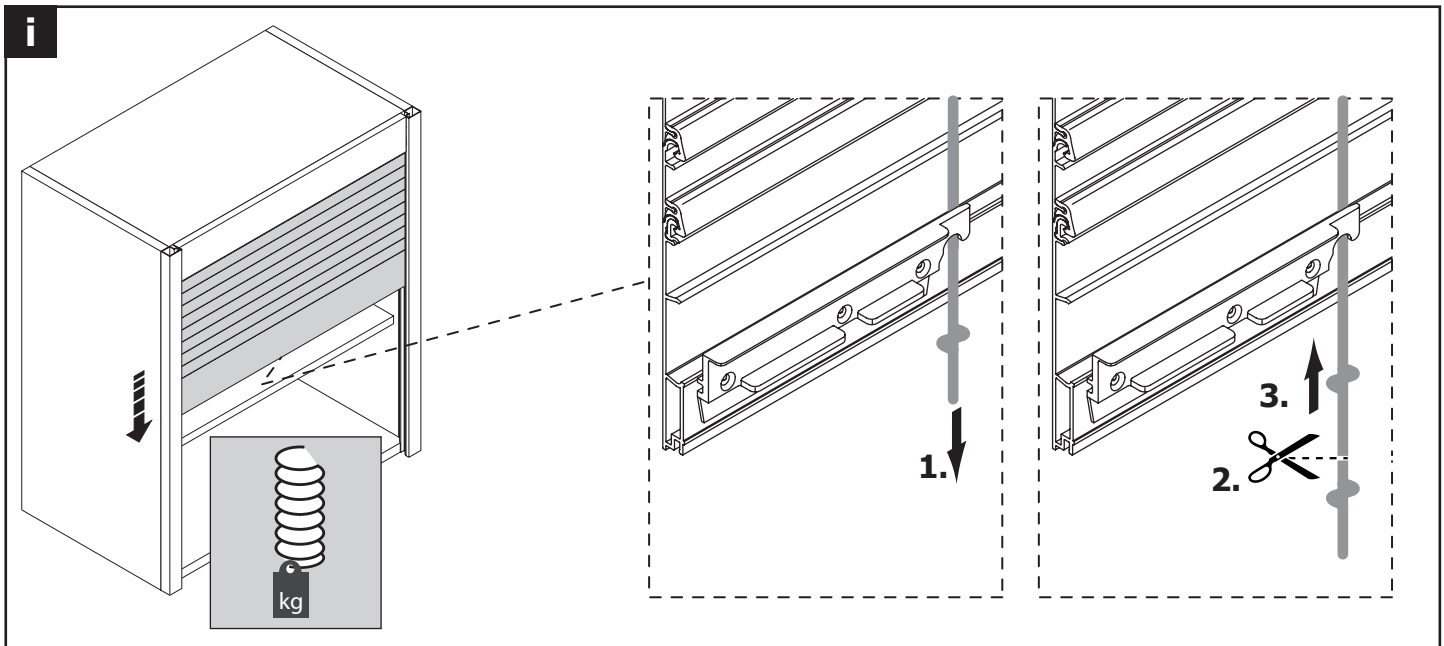

**DE**

Die Abb. zeigt die Einstellung der Federkraft. Bei der Einstellung ist die DIN 14749 zu beachten. Die Federkraft soll den Rollläden im Gleichgewicht halten. Soll sich jedoch der Rollladen selbsttätig absenken, muss die Federkraft so eingestellt werden, dass die Bewegung spätestens 200 mm vor dem vollständig geschlossenen Zustand von allein stoppt.

**GB**

The image shows the adjustment of the spring force. When doing the setting please note DIN 14749. The spring force should keep the roller shutter in balance. However, if the roller shutter lowers itself automatically, the spring force has to be adjusted in such a manner, that the movement will stop on its own the latest 200 mm before the roller shutter will be closed completely.



DE

GB

**Wichtiger Hinweis:**

Die folgende Darstellung zeigt den Einfluß des Schlosses auf die Schrankkonstruktion. Die Maßangaben beruhen auf Herstellerangaben sowie eigenen Versuchen. Sie geben den aktuellen Kenntnisstand wieder. Trotz sorgfältiger Prüfung übernehmen wir keine Garantie für die Vollständigkeit und Richtigkeit der Angaben.

**Important note:**

The following illustration shows the influence of the lock on the cabinet construction. The measurements are based on manufacturers specifications as well as own tests. They reflect the current level of knowledge. Despite careful examination we provide no guarantee for the completeness and correctness of this information.

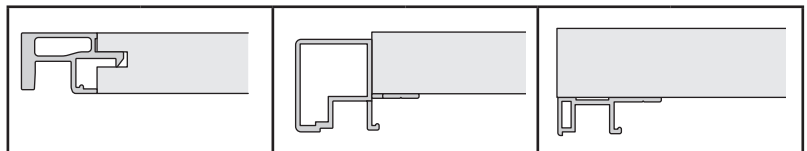
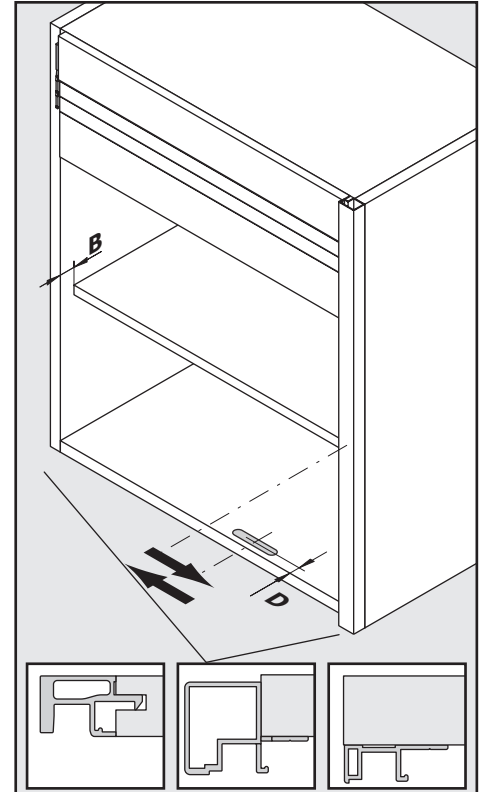
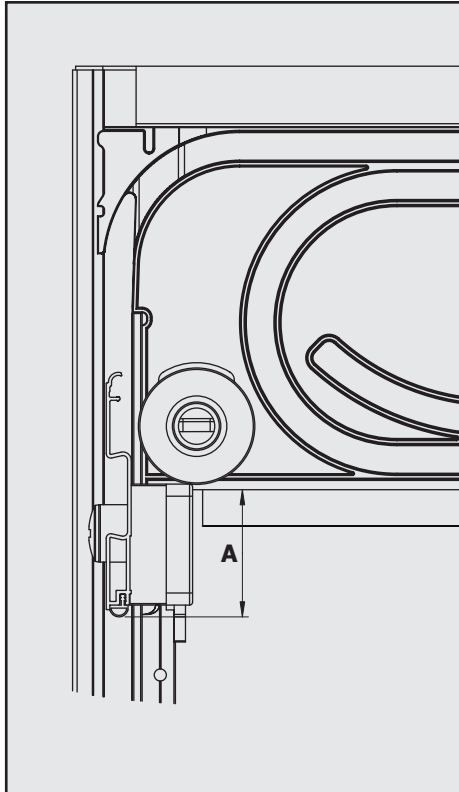
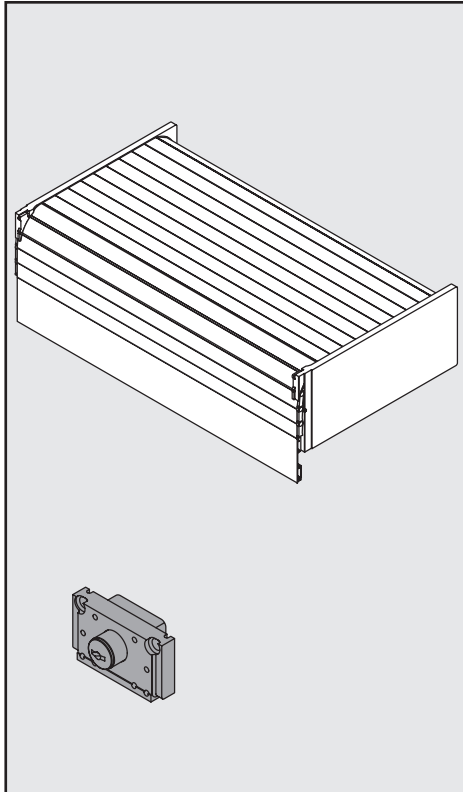

	Schloss / lock	A (mm)	B min (mm)	D (mm)	B min (mm)	D (mm)	B min (mm)	D (mm)
	Lehmann Prestige P2 Type 416 oder ähnlich (or similar)	41	XXX	XXX	16,5	7,6	32	23,6
	Lehmann Prestige P2 Type 292 oder ähnlich (or similar)	42	13	XXX	16	XXX	33	XXX
	Häfele Symo 232.30.620 oder ähnlich (or similar)	44,5	XXX	XXX	22	14,2	37,5	30,2
	Häfele Symo 237.76.620 oder ähnlich (or similar)	51,5	13	XXX	13	XXX	29	XXX
	Hekna 1280 F oder ähnlich (or similar)	43,5	XXX	XXX	22	14,2	37,5	30,2
	Hekna 630 oder ähnlich (or similar)	25	13	XXX	13	XXX	29	XXX
	Heusser Für KABA 1057/1008 C oder ähnlich (or similar)	34	14,5	XXX	20	XXX	35,5	XXX



DE

GB

**Wichtiger Hinweis:**

Die folgende Darstellung zeigt den Einfluß des Schloßes auf die Schrankkonstruktion. Die Maßangaben beruhen auf Herstellerangaben sowie eigenen Versuchen. Sie geben den aktuellen Kenntnisstand wieder. Trotz sorgfältiger Prüfung übernehmen wir keine Garantie für die Vollständigkeit und Richtigkeit der Angaben.

**Important note:**

The following illustration shows the influence of the lock on the cabinet construction. The measurements are based on manufacturers specifications as well as own tests. They reflect the current level of knowledge. Despite careful examination we provide no guarantee for the completeness and correctness of this information.

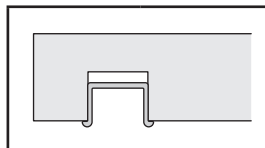
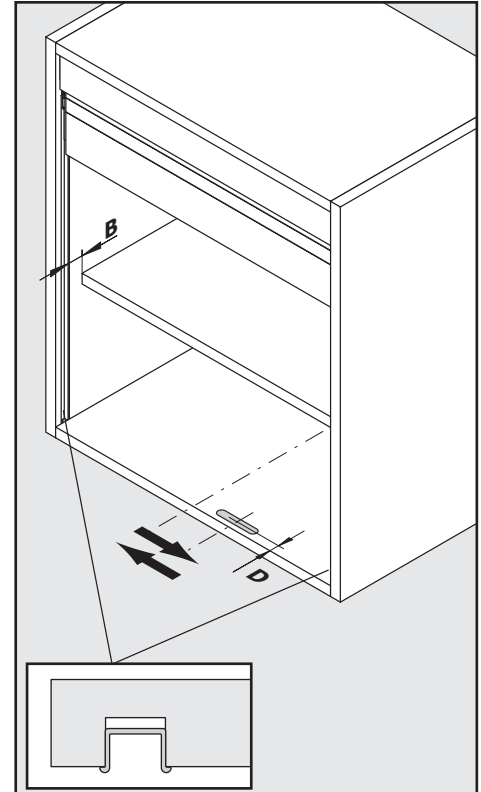
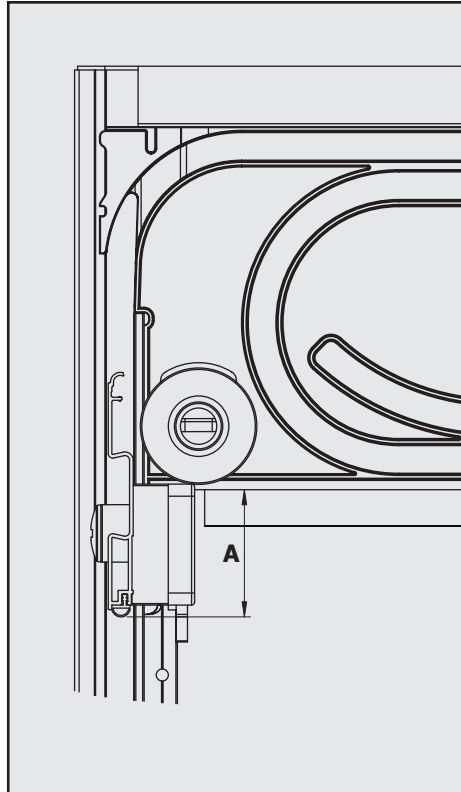
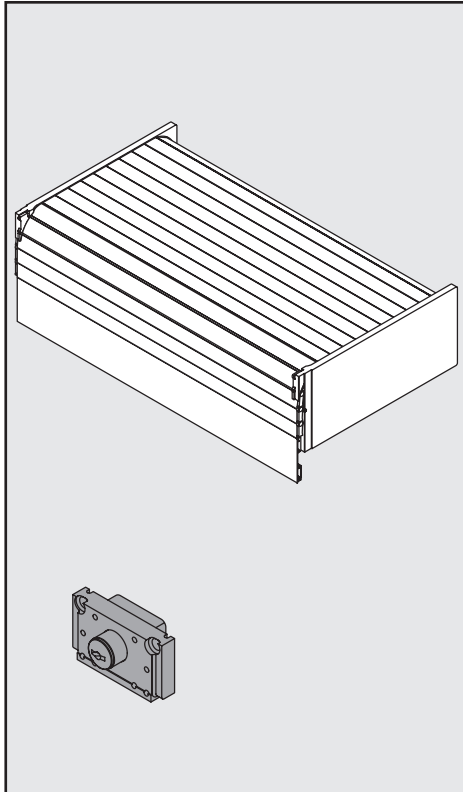

	Schloss / lock	A (mm)	B min (mm)	D (mm)
<input type="checkbox"/>	Lehmann Prestige P2 Type 416 oder ähnlich (or similar)	41	16,5	7,6
<input type="checkbox"/>	Lehmann Prestige P2 Type 292 oder ähnlich (or similar)	42	16	XXX
<input type="checkbox"/>	Häfele Symo 232.30.620 oder ähnlich (or similar)	44,5	22	14,2
<input type="checkbox"/>	Häfele Symo 237.76.620 oder ähnlich (or similar)	51,5	13	XXX
<input type="checkbox"/>	Hekna 1280 F oder ähnlich (or similar)	43,5	22	14,2
<input type="checkbox"/>	Hekna 630 oder ähnlich (or similar)	25	13	XXX
<input type="checkbox"/>	Heusser Für KABA 1057/1008 C oder ähnlich (or similar)	34	20	XXX